

ELEVATION

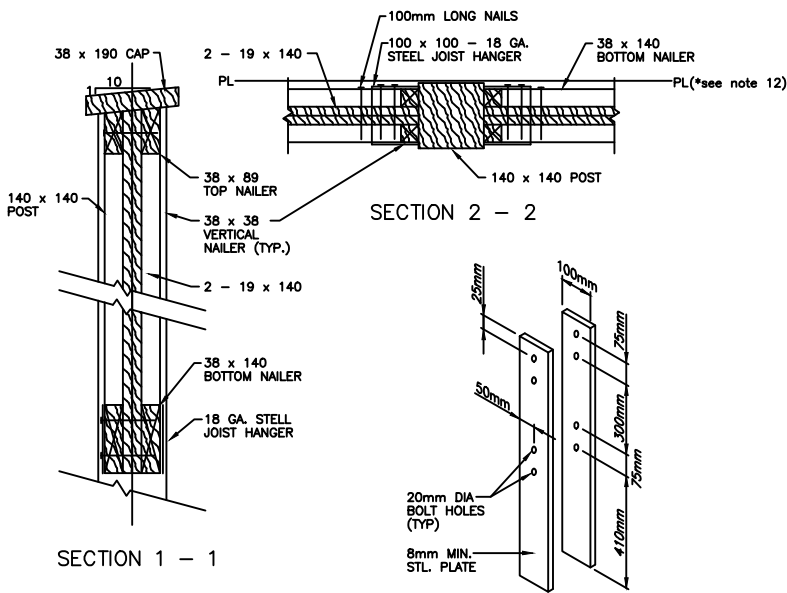

SECTION 2 - 2

SECTION 1 - 1

ANCHOR STRAPS DETAIL

NOTES FOR ANCHOR STRAPS DETAIL:

1. ANCHOR STRAPS TO BE HOT DIPPED GALVANIZED.
2. 4 - 16mm (5/8") DIA. BOLTS c/w NUTS & WASHER REQ'D. FOR ANCHOR STRAPS.
3. TIE STRAPS TOGETHER WITH REBAR.

GENERAL CONSTRUCTION NOTES

1. CONCRETE MATERIAL QUALITY, MIXING, PLACING & OTHER CONSTRUCTION PRACTICES TO CONFORM TO C.S.A. STANDARD CAN3-A23.1.
2. USE TYPE 50 PORTLAND CEMENT MEETING THE REQUIREMENTS OF C.S.A. STANDARD A5. CONCRETE STRENGTH TO BE A MINIMUM 25 Mpa AT 28 DAYS WITH A MAXIMUM SLUMP OF 100mm.
3. AIR ENTRAINMENT TO BE 5 - 7% CONFORMING TO THE REQUIREMENTS OF A.S.T.M. DESIGNATION C260.
4. REINFORCING STEEL TO BE INTERMEDIATE GRADE DEFORMED BARS MEETING THE REQUIREMENTS OF C.S.A. STANDARD G30.18M GRADE 400
5. ALL LUMBER, SUBJECT TO APPROVAL OF THE ENGINEER WITH RESPECT TO QUALITY, MOISTURE CONTENT & APPEARANCE TO BE SPECIFIED IN ACCORDANCE WITH C.S.A. STANDARD O 141
 - (a) BOARDS TO BE STRUCTURAL GRADE S-P-F DESIGNATION CSAI-686-M88
 - (b) POST TO BE No. 1 STRUCTURAL GRADE S-P-F DESIGNATION CSAI-686-M88 AND PRESSURE TREATED.
 - (c) ALL LUMBER TO BE KILN DRIED TO 19% MOISTURE CONTENT PRIOR TO ERECTION.
6. (a) PRESSURE TREAT ENTIRE NOISE BARRIER WOOD PRIOR TO FIELD ASSEMBLY. KILN DRY AFTER PRESSURE TREATMENT TO 19% MOISTURE CONTENT. PRESSURE TREATMENT TO BE CHROMATED COPPER ARSENATE (C.C.A.).
OR
(b) PRESSURE TREAT ENTIRE NOISE BARRIER WOOD PRIOR TO FIELD ASSEMBLY. KILN DRY AFTER PRESSURE TREATMENT TO 19% MOISTURE CONTENT. PRESSURE TREATMENT TO BE 'WOLMANIZED CEDAR TONE' TO C.S.A. STANDARDS PS-74 & C.S.A. 080.1.
7. ALL NAILS TO BE GALVANIZED SCREW NAILS
8. ALL STEEL AND BOLTS TO BE GALVANIZED.
9. ALL STEEL TO CONFORM TO C.S.A. G40.21-M, STRUCTURAL QUALITY STEELS.
10. GALVANIZING TO CONFORM TO C.S.A. G164.
11. ALL LUMBER TO HAVE TWO COATS OF APPROVED STAIN.
12. FENCE TO BE LOCATED WITHIN ROAD RIGHT OF WAY UNLESS APPROVED OTHERWISE.

Dimensions are in mm unless otherwise noted.

				Drawn	Date	Chk'd	Sheet
				ACC	Nov/11	ACC	
				Scale: NTS Approved by: BN			
NO.	DATE	REVISIONS	APP'D				File Number
							R0004